

IoT-Based Sleep Quality Monitoring System With Sleep Condition Analysis Using Fuzzy Logic

Muhammad Lutfi Mahasinul Akhlak^{a*}

^aInformation Technology STMIK Bina Patria, Magelang, 56116, Central Java

Received 27 February 2026; Revised 03 Mart 2026; Accepted 18 Mart 2026; Published 01 April 2026

Abstract

This research aims to develop a low-cost IoT-based sleep quality Monitoring System with Sleep Condition analysis using fuzzy logic for real-time physiological data acquisition and classification. The study employed the ADDIE development model (Analysis, Design, Development, Implementation, Evaluation). The system integrates MAX30100 heart rate sensor, DHT22 temperature sensor, and MPU6050 motion sensor with an ESP32 microcontroller. A Mamdani fuzzy inference system was implemented to classify Sleep Conditions based on heart rate, body temperature, and body movement parameters. The system was simulated using Wokwi and Cisco Packet Tracer, with fuzzy rules developed in MATLAB and embedded programming in Arduino IDE. The Blynk IoT platform was utilized for remote monitoring. Validation included Black Box Testing and User Acceptance Testing (UAT) with ten respondents. The system successfully acquired real-time physiological data and transmitted it to the Blynk cloud platform. The fuzzy logic algorithm effectively processed sensor data uncertainty, classifying health conditions into "Healthy," "Warning," or "Critical" status. Black Box Testing confirmed all main functions operated according to specifications. UAT yielded an 88% satisfaction score, indicating the system is highly feasible, user-friendly, and beneficial for independent sleep monitoring. This research contributes a practical, affordable IoT-based sleep monitoring architecture integrating fuzzy logic for Sleep Condition classification on embedded systems, offering an accessible alternative to conventional clinical methods for personal health management.

Keywords: Internet of Things, Sleep Quality Monitoring, Fuzzy Logic, Sleep Condition Analysis, Mamdani Inference System.

1. Introduction

Sleep plays a fundamental role in maintaining human health, cognitive performance, and overall well-being. Poor sleep quality has been associated with various health problems, including cardiovascular diseases, metabolic disorders, fatigue, and reduced productivity. In recent years, sleep disorders such as insomnia, sleep apnea, and restless sleep have become increasingly prevalent due to modern lifestyles and work patterns [1].

Traditional sleep monitoring methods such as polysomnography (PSG) are widely used in clinical environments to analyze Sleep Conditions and detect sleep disorders. However, these systems require specialized medical equipment, controlled laboratory environments, and expert supervision, which makes them impractical for continuous monitoring in everyday settings.

Recent advancements in **Internet of Things (IoT)** technologies have enabled the development of smart healthcare Monitoring Systems capable of collecting physiological data in real time using connected sensors. IoT-based health monitoring solutions allow physiological parameters such as heart rate, body temperature, and body movement to be continuously measured and transmitted to cloud platforms for analysis and visualization. These systems provide an affordable and accessible alternative to traditional clinical monitoring methods.

Several studies have explored IoT-based sleep Monitoring Systems using wearable sensors and machine learning algorithms. For example, IoT systems integrated with physiological sensors have been used to analyze sleep patterns and detect sleep disorders with high accuracy through cloud-based monitoring platforms. However, many existing approaches rely on computationally intensive machine learning models or expensive wearable devices, which may limit their practical implementation in low-cost embedded systems.

To address these challenges, lightweight decision-making methods such as **fuzzy logic** have been widely applied in IoT-based health Monitoring Systems [2], [3]. Fuzzy logic is capable of handling uncertainty and imprecise physiological data by modeling human reasoning through rule-based inference systems. Previous studies have demonstrated that fuzzy logic can effectively classify physiological conditions and support real-time health monitoring applications [4].

Therefore, this study proposes an **IoT-based sleep quality Monitoring System integrated with fuzzy logic for**

Sleep Condition analysis. The proposed system utilizes physiological sensors including a **MAX30100 heart rate sensor**, **DHT22 temperature sensor**, and **MPU6050 motion sensor** connected to an **ESP32 microcontroller**. A **Mamdani fuzzy inference system** is implemented to classify Sleep Conditions based on physiological parameters. The system is integrated with the **Blynk IoT cloud platform** to provide real-time monitoring through a mobile dashboard.

The main contributions of this research are summarized as follows:

- a. Development of a **low-cost IoT-based sleep monitoring architecture** using physiological sensors and ESP32 microcontroller.
- b. Implementation of a **Mamdani fuzzy inference system** for Sleep Condition classification based on heart rate, body temperature, and body movement.
- c. Integration of the Monitoring System with a **cloud-based IoT platform for real-time visualization and monitoring**.
- d. Validation of the proposed system through **Wokwi System and hardware prototype implementation**.

The remainder of this paper is organized as follows. Section II discusses related work on IoT-based sleep Monitoring Systems. Section III describes the proposed system architecture. Section IV explains the research methodology and fuzzy logic model. Section V presents system implementation. Section VI discusses the experimental results. Finally, Section VII concludes the paper and outlines future research directions.

2. Methode

The following is the framework of the research method used

2.1. System Architecture

The proposed system is designed as an Internet of Things (IoT)-based sleep monitoring platform that integrates physiological sensors, a microcontroller unit, cloud infrastructure, and a fuzzy logic-based decision system.

The overall architecture consists of three main layers:

- a. Data Acquisition Layer
This layer collects physiological and environmental data during sleep. The sensors used include; Heart rate sensor, Body movement sensor and Ambient temperature and humidity sensor. These sensors continuously monitor user conditions and transmit raw data to the microcontroller.
- b. Processing and Communication Layer
A microcontroller (ESP32) is used to: Read sensor data in real time, Perform initial preprocessing, Send data to a cloud server via Wi-Fi using internet protocol (*Blynk*)
- c. Application and Analysis Layer
This layer performs: Data storage (cloud database such as Blynk, Sleep quality analysis using a fuzzy inference system and Visualization through a mobile/web dashboard

2.2. System Workflow

The system workflow is illustrated as follows: Sensors collect physiological and environmental data, Data is transmitted to the microcontroller, Data is sent to the cloud server, Fuzzy logic analyzes sleep conditions and Sleep quality results are displayed to the user

2.3. Fuzzy Logic Algorithm Design

The fuzzy logic system is used to classify sleep quality based on multiple input parameters. The system uses three main input variables Heart Rate (HR), Body Movement (BM) and Room Temperature (RT). Membership Functions use Triangular and trapezoidal membership functions are used. The system applies IF–THEN rules to infer sleep quality.

A total of 7 rules are defined to cover all conditions. The fuzzy inference system uses **Mamdani method**

2.4. Implementation

The hardware system is implemented using SBC-PT (SBC0) connected to a Motion Sensor, Temperature Sensor, Generic Sensor (Heart Rate), LCD (IoT1), DLC100 WiFi, which connects wirelessly to a Temperature Monitor (IoT0) and a Smartphone. All components are integrated into a wearable or bedside device.

The software stack implementation includes Arduino IDE (firmware programming), Cisco Packet Tracer, Matlab, Blynk, make proto and wokwi

2.5. Testing and Validation

Testing is carried out using black box testing, namely testing to see the hardware readiness of the system. The system validation is tested using Real user sleep data, Comparison with standard sleep indicators and Accuracy evaluation of fuzzy classification.

3. Result

Result of the research refer to the stages of method;

3.1. System Architecture

The first stage in this research is to analyze the need for developing a new product and requirements for product development. The development of a product can be initiated by problems in existing/deployed products.

Table 1. Needs Analysis for the IoT-based sleep quality Monitoring System with Sleep Condition analysis using fuzzy logic

No.	System Requirement	Type of Requirement	Description
1	Heart Rate Sensor	Hardware	Uses an MAX30100 sensor to detect the user's heart rate.
2	Temperature Sensor	Hardware	Uses an DHT22 temperature sensor (U1) to measure temperature.
3	Microcontroller	Hardware	Uses an ESP32 to process data and a Wi-Fi communication module from the sensor and control the display on the LCD.
4	Local Display	Hardware	Uses a 20x4 LCD to display sensor reading data directly.
5	Data Processing Logic	Hardware	Program on the ESP32 that reads data from analog pins, processes it into information (BPM & temperature), and sends it to the LCD.
6	Stable Power Supply	Hardware	Required to ensure the ESP32, sensors, and LCD operate normally without interruption.
7	Sensor Calibration	Non-Functional	Sensors need to be calibrated to ensure accurate temperature and heart rate readings.
8	Clarity of Information	Non-Functional	The display on the LCD must be clear and easy for the user to read.
9	Mamdani Fuzzy Logic	Software	Monitoring and manual control media via smartphone and desktop applications.
10	Wokwi and Arduino IDE	Software	Tools for circuit System and program code development (C++).

3.2. Design

The design stage is a systematic process starting with designing the concept and content within the product, which will form the basis for the development process in the subsequent stage. In this research, the design stage was carried out by designing instruments consisting of software and hardware. The software used includes Cisco Packet Tracer, Matlab 2020b, Wokwi, and Arduino IDE. The hardware consists of electronic components forming the Monitoring System, including an ESP32 microcontroller, Heart Rate Sensor, Body Temperature Sensor, Motion Sensor, LCD, WiFi module (DLC100), and Smartphone. Software instruments are used to design the hardware (using Wokwi), design the Mamdani Fuzzy Logic rules (using Matlab 2020b), and create the program code (using Arduino IDE). Meanwhile, the IoT system is designed using the Cisco Packet Tracer program, and the user interface is designed using the Blynk application.

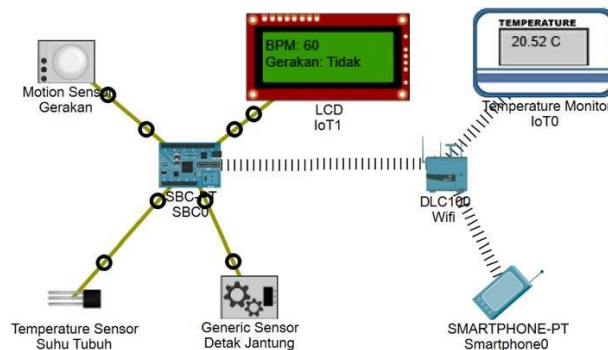

Figure 2. IoT Scheme Design for the IoT-Based Sleep Quality Monitoring System with Sleep Condition Analysis using Fuzzy Logic, created with Cisco Packet Tracer software.

(Description: A network diagram in Cisco Packet Tracer showing components: SBC-PT (SBC0) connected to a Motion Sensor, Temperature Sensor, Generic Sensor (Heart Rate), LCD (IoT1), DLC100 WiFi, which connects wirelessly to a

Temperature Monitor (IoT0) and a Smartphone (SMARTPHONE-PT).)

Table 2. IoT Scheme Device for the IoT-Based Sleep Quality Monitoring System with Sleep Condition Analysis using Fuzzy Logic, created with Cisco Packet Tracer software.

No.	Device	Description
1	SBC-PT (SBC0)	Acts as the central control unit (brain) of the system that receives data from sensors (motion, temperature, heart rate), processes it, and displays it on the LCD.
2	Motion Sensor	A sensor that functions to detect the presence or absence of movement from the user.
3	Temperature Sensor	A sensor that functions to measure the user's body temperature in real-time.
4	Generic Sensor (Heart Rate)	A sensor used to measure the user's heart rate in BPM (Beats Per Minute).
5	LCD (IoT1)	A local display screen to show processed information, such as BPM and movement status, directly to the user.
6	DLC100 Wifi	A wireless communication module that connects the system to other devices like the Temperature Monitor and Smartphone for data transmission.
7	Temperature Monitor (IoT0)	A device for remote temperature monitoring that receives data wirelessly from the system.
8	Smartphone (SMARTPHONE-PT)	A device used by the user to access and monitor data from the system remotely via a wireless connection.

After designing the Internet of Things devices for the system, the next stage is to create a fuzzy rule base. These rules are the core of the inference system that will determine the Sleep Condition based on physiological data from the sensors.

Table 3. Rule for the IoT-Based Sleep Quality Monitoring System with Sleep Condition Analysis using Fuzzy Logic

Rule	Description
Rule 1	If Heart Rate is Low (40-98 BPM) AND Body Temperature is Normal (35.6-41.4 °C), then the system will determine a Healthy condition (Nyenyak) as an indicator that the body is in an ideal resting state.
Rule 2	If Heart Rate is Low (40-98 BPM) AND Body Temperature is Cool (35-37.9 °C), then the system still determines a Healthy (Nyenyak) condition (Nyenyak) as an indication that the body is resting in a cool environment.
Rule 3	If Heart Rate is Normal (52-168 BPM) AND Body Temperature is Normal (35.6-41.4 °C), then the system will give a Warning status (Mimpi) to mark the potential for a minor anomaly during sleep.
Rule 4	If Heart Rate is Low (40-98 BPM) but Body Temperature is Normal (35.6-41.4 °C), then the system will give a Warning status (Mimpi) as a signal of a combination that requires attention.
Rule 5	If Heart Rate is High (122-180 BPM) even though Body Temperature is Normal, then the system will directly conclude a Critical condition (Bangun atau Terjaga) as an indication of severe physiological stress.
Rule 6	If Heart Rate is High (122-180 BPM) accompanied by Body Temperature being Hot (39.1-42 °C), then the system will conclude a Critical condition (Bangun atau Terjaga) as a medical emergency signal (e.g., high fever during sleep).
Rule 7	If Heart Rate is Normal (52-168 BPM) and Body Temperature is being Hot (39.1-42 °C), then the system will conclude a Critical condition (Bangun atau Terjaga) as a marker of a hidden anomaly considered serious by the system.

3.3. Development

The development stage involves the activities of realizing the product design that was previously created. In this research, the development stage was carried out by developing the product design, which consists of the IoT design,

application interface design, hardware design, and fuzzy design [9].

3.3.1. Overall System Architecture

This sleep quality Monitoring System is designed with a modular architecture integrating sensor data acquisition, microcontroller processing, wireless communication, an Internet of Things (IoT) platform, and a user interface. The main components include:

- a. **Sensor Data Acquisition Module:** Collects important physiological data from a heart rate sensor (MAX30100), a body temperature sensor (DHT22), and a motion sensor (Cisco Motion Sensor) as indicators of Sleep Conditions.
- b. **Microcontroller (ESP32):** Acts as the brain of the system, tasked with reading and processing sensor data (including filtering and smoothing), implementing fuzzy logic, and transmitting data.
- c. **Communication Module (DLC100 Wifi):** Enables Wi-Fi connectivity to transmit data wirelessly to the IoT platform.
- d. **IoT Platform (Blynk):** Functions as a central data storage and management point for data received from the microcontroller.
- e. **Monitoring Application (Smartphone):** A smartphone application or web interface that displays real-time data (heart rate, temperature, movement), Sleep Condition analysis results, and historical data trend graphs to the user.
- f. **Local Display (LCD1 20x4 LCD):** An LCD screen on the device to display basic information and status directly to the user.

3.3.2. Implementation of Fuzzy Logic for Sleep Condition Analysis

Effective Sleep Condition analysis requires handling physiological data that often has vague boundaries and varies between individuals [1]. Therefore, fuzzy logic is implemented as the core of the analysis system. This approach allows for a more nuanced interpretation of sleep conditions than rigid threshold-based methods.

- a. **Heart Rate (BPM):** Heart rate tends to slow down as a person enters deeper sleep phases, making it an important indicator.
- b. **Body Temperature:** Core body temperature shows a significant decrease during deep sleep.
- c. **Body Movement:** The frequency and intensity of movements indicate whether an individual is in deep sleep, REM (Rapid Eye Movement) sleep, or awake.
- d. **Fuzzy Rule Base:** Creating "IF-THEN" rules that describe the relationship between input and output variables. Example rules:
 - 1) IF (Heart Rate is Low) AND (Body Temperature is Low) AND (Movement is Very Low) THEN (Sleep Condition is Deep Sleep).
 - 2) IF (Heart Rate is Medium) AND (Body Temperature is Normal) AND (Movement is Medium) THEN (Sleep Condition is REM).
 - 3) IF (Heart Rate is High) AND (Body Temperature is Normal) AND (Movement is High) THEN (Sleep Condition is Awake).
- e. **Fuzzy Inference:** Applying the fuzzy rules to determine the truth level for each rule.
- f. **Defuzzification:** This final step converts the linguistic output back into a numerical value that can be interpreted, such as sleep quality status (e.g., Very Good, Good, Fair, Poor) or specific Sleep Conditions (Stage 1, Stage 2, Deep Sleep, REM, Awake).

3.3.3. Development of Fuzzy Logic Inputs, Outputs, and Rules

This section discusses the design of the fuzzy inference system, which is the core of the Sleep Condition analysis. Fuzzy logic is used to handle uncertainty and ambiguity in physiological sensor data, enabling more accurate Sleep Condition determination compared to traditional binary methods.

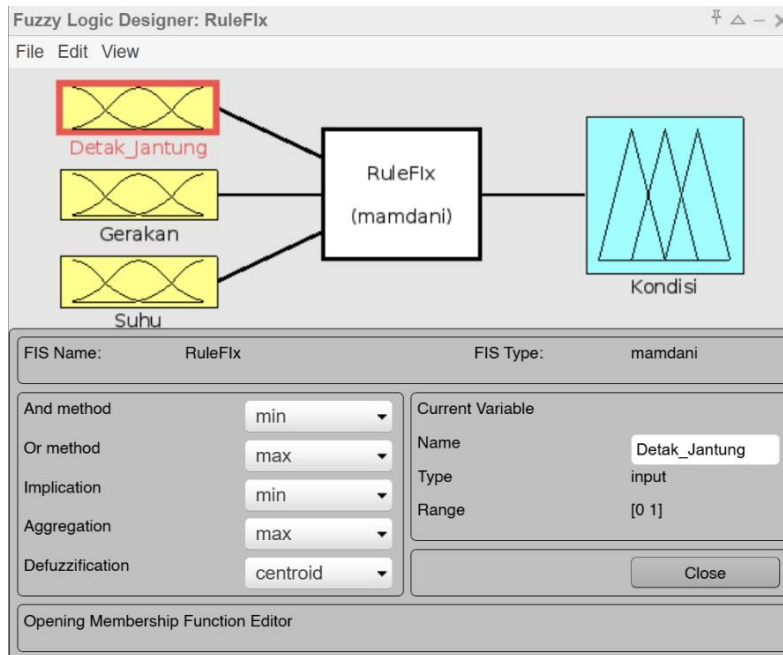

Figure 3. Inputs and Outputs of the IoT-Based Sleep Quality Monitoring System with Sleep Condition Analysis using Fuzzy Logic, displayed in Matlab.

Description: A screenshot of the Matlab Fuzzy Logic Designer showing the system with three inputs: "Detak_Jantung" (Heart Rate), "Gerakan" (Movement), "Suhu" (Temperature) and one output: "Tahapan_Tidur" (Sleep Condition).

The input data consists of three types: heart rate, movement, and temperature. The following is the display of the sensor input for the sleep quality Monitoring System using the fuzzy method. This method has three membership function graphs: low, medium, and high, with a range between 40% and 80%. Below is an image showing the display:

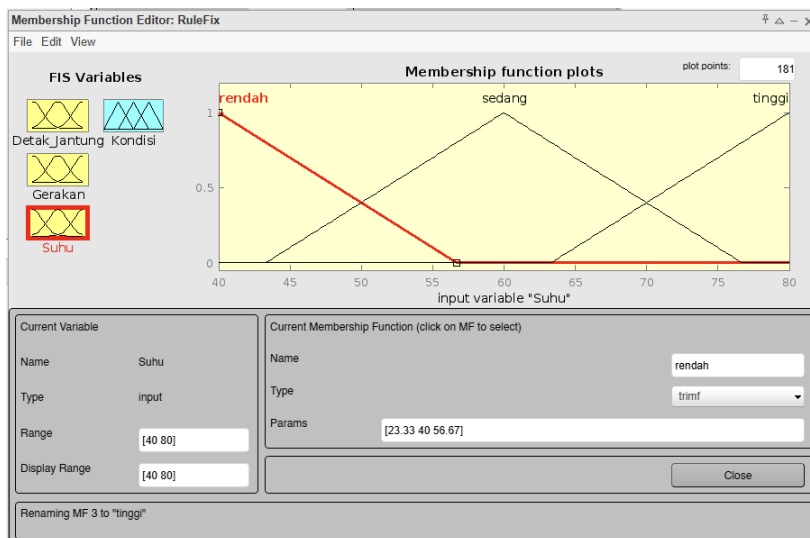

Figure 4. Temperature Range of the IoT-Based Sleep Quality Monitoring System with Sleep Condition Analysis using Fuzzy Logic, displayed in Matlab.

Description: Membership function plot for the "Suhu" (Temperature) input, showing three curves for "Dingin" (Cold), "Normal", and "Panas" (Hot) over a range of 35-42 °C.

Next is how the input from the motion sensor is displayed using fuzzy logic, which has three membership function graphs: none, little, and a lot. Below is an image of the display:

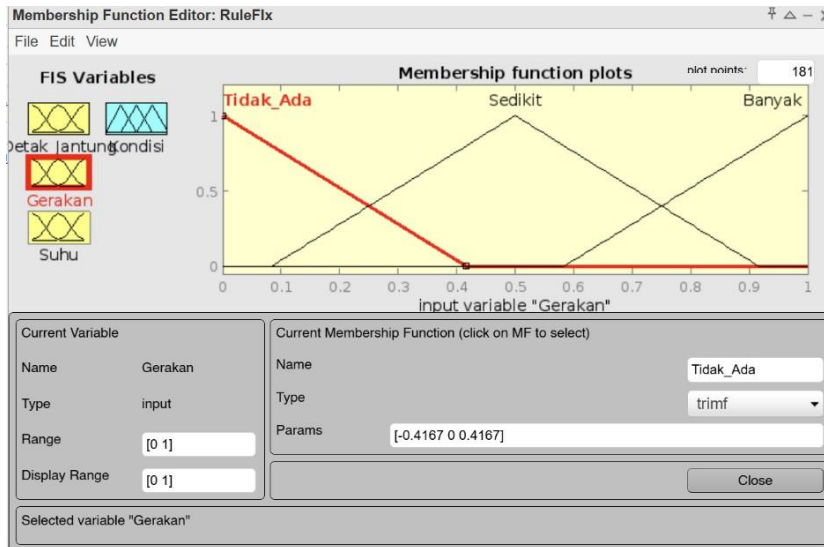

Figure 5. Movement Range of the IoT-Based Sleep Quality Monitoring System with Sleep Condition Analysis using Fuzzy Logic, displayed in Matlab.

(Description: Membership function plot for the "Gerakan" (Movement) input, showing three curves for "Tidak Ada" (None), "Sedikit" (Little), and "Banyak" (A lot) over a range of 0-10, likely representing movement intensity.) Next is how the input from the heart rate sensor is displayed using fuzzy logic, which has three membership function graphs: low, medium, and high, with a range between 60 and 200. Below is an image of the display:

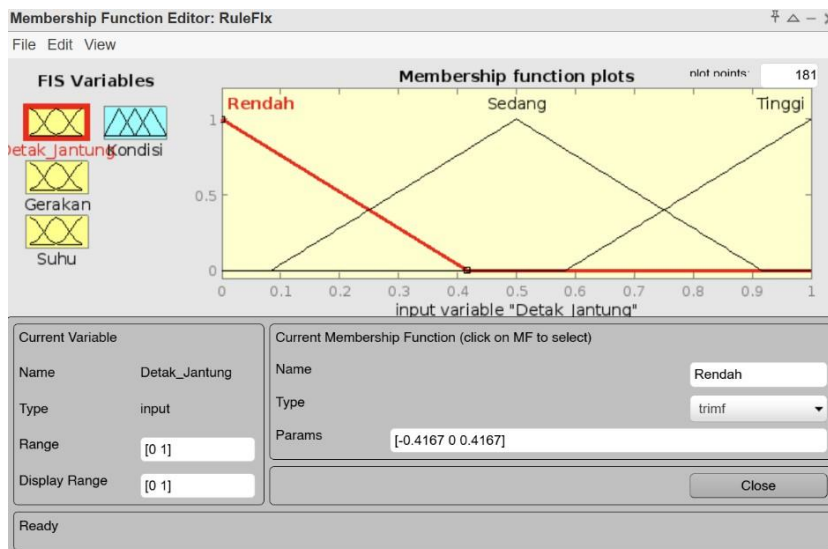

Figure 6. Heart Rate Range of the IoT-Based Sleep Quality Monitoring System with Sleep Condition Analysis using Fuzzy Logic, displayed in Matlab.

(Description: Membership function plot for the "Detak_Jantung" (Heart Rate) input, showing three curves for "Rendah" (Low), "Sedang" (Medium), and "Tinggi" (High) over a range of 60-200 BPM.)

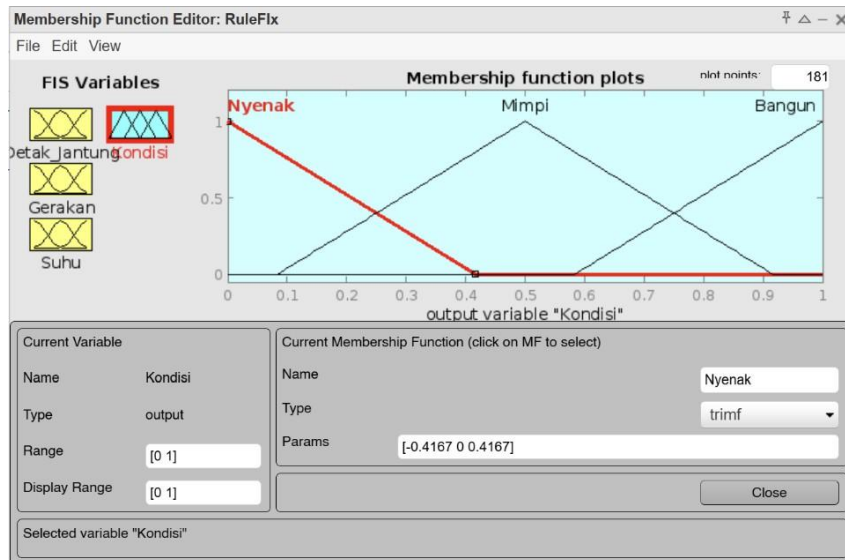

Figure 7. Output (Sleep Conditions) of the IoT-Based Sleep Quality Monitoring System with Sleep Condition Analysis using Fuzzy Logic, displayed in Matlab.

(Description: Membership function plot for the output "Kondisi" (Sleep Condition), showing three curves: **Healthy** condition (Nyenyak), **Warning** status (Mimpi) and **Critical** condition (Bangun atau Terjaga).

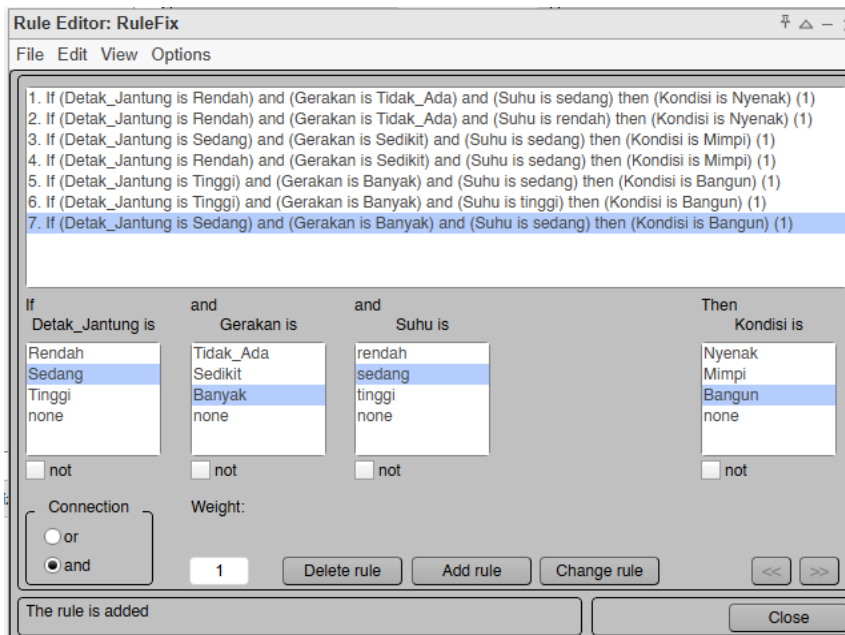

Figure 8. Rules of the IoT-Based Sleep Quality Monitoring System with Sleep Condition Analysis using Fuzzy Logic, displayed in Matlab.

(Description: The Rule Viewer in Matlab, showing a matrix of rules and the resulting aggregated output for a specific set of inputs.)

3.3.4. Development of Fuzzy Programming for Arduino

The results of the fuzzy logic rule development in Matlab software were then converted to be readable in the Arduino IDE software. This image shows the result of converting the .fis file into an .ino file format, which can be read using the Arduino IDE software and subsequently uploaded to the Wokwi application.

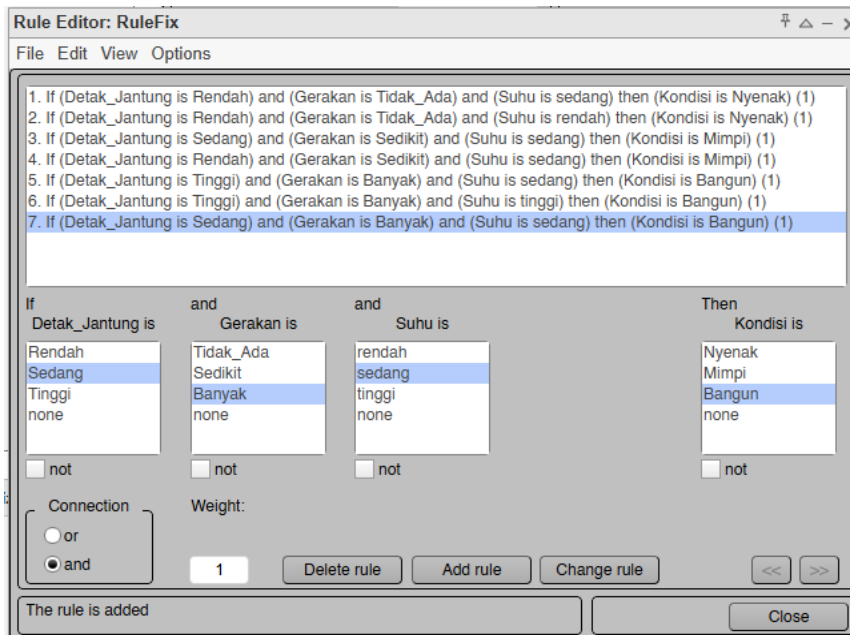

Figure 9. Program Code for the IoT-Based Sleep Quality Monitoring System with Sleep Condition Analysis using Fuzzy Logic, displayed in Arduino IDE

3.4. Implementation

This section describes the implementation of the hardware and part of the software for the heart rate and temperature Monitoring System simulated using Wokwi for real-time data monitoring. This System serves to validate the basic functionality of the system before implementation on physical hardware.

3.4.1. System System Before Start

This image shows the System design of the physiological data acquisition system using the Wokwi platform. The main components include an ESP32 as the main microcontroller, a heart rate sensor module (red) and a temperature sensor module (blue) as vital data inputs. The acquired data will be processed and displayed in real-time on a 20x4 LCD connected via an I2C interface. Additionally, there is a green push button that functions as a trigger to start the measurement process. This System represents the basic hardware configuration for digitally processing and visualizing heart rate and body temperature data.

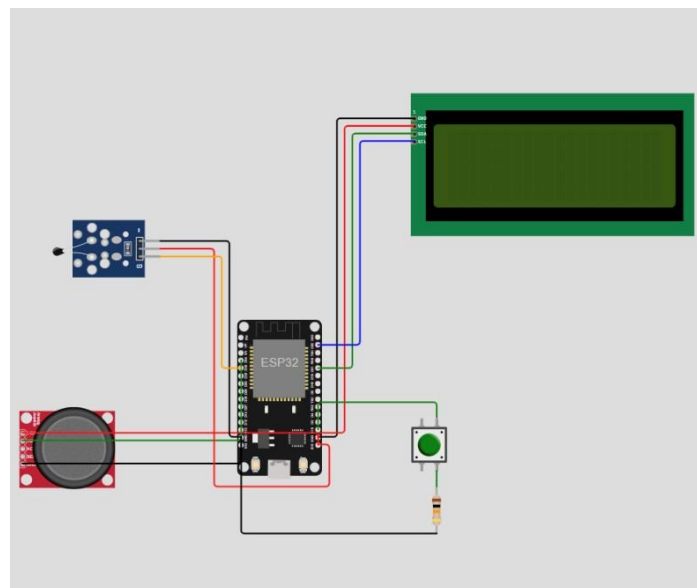

Figure 10. System System on Wokwi Before Start.

(Description: The Wokwi System interface showing the circuit diagram with ESP32, sensors, LCD, and button, with the LCD showing default/blank values like "BPM: 0".)

3.4.2. System System When Heart Rate is Off

In this System stage, the system is tested under the specific condition where the heart rate sensor is inactive or does not detect a pulse. As shown on the LCD screen, the system accurately responds by showing a value of 0 for the Beats Per Minute (BPM) parameter, validating the program's ability to handle the absence of a signal. Simultaneously, the DHT22 temperature sensor continues to function normally and continuously updates the temperature data, proving that each component can work independently and the system remains stable even when one sensor input is zero.

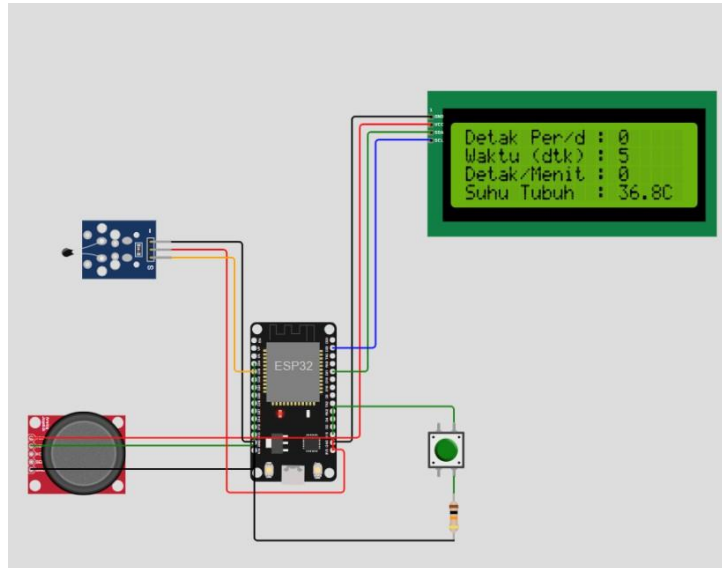

Figure 11. System System on Wokwi When Heart Rate is Off.

(Description: The Wokwi System, likely with the LCD showing BPM: 0 and a valid temperature reading.)

3.4.3. System System When Heart Rate is On

In the next System stage, the system was tested in an active condition, where heart rate input was simulated by rhythmically pressing the trigger button (push button). As seen on the LCD, the system successfully detected the button interrupts, counted the tap frequency, and converted it into a valid BPM value. The system then displayed the health condition analysis result (e.g., "PERINGATAN" / WARNING) based on the embedded fuzzy logic rules. This System proves that the ESP32 is capable of multitasking: reading digital (heart rate) and analog (temperature) inputs, processing the fuzzy algorithm, and updating the output display in real-time and accurately.

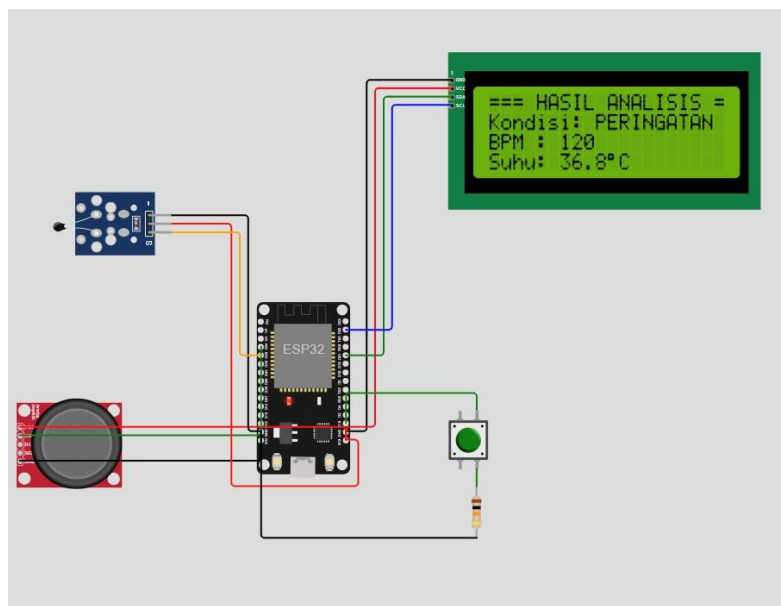

Figure 12. System System on Wokwi When Heart Rate is On.

(Description: The Wokwi System with the LCD actively showing a BPM value (e.g., 82) and a status like "PERINGATAN".)

This system was integrated with the Blynk application as the user interface for system monitoring. This Blynk platform is configured to display the user's physiological data in real-time, including heart rate (BPM) and body temperature. Furthermore, Blynk also displays the health condition status (Healthy, Warning, or Critical) as the output of the fuzzy logic processing performed by the ESP32 microcontroller. This integration makes it easy for users to monitor sleep quality and health conditions independently and remotely via smartphone devices efficiently.

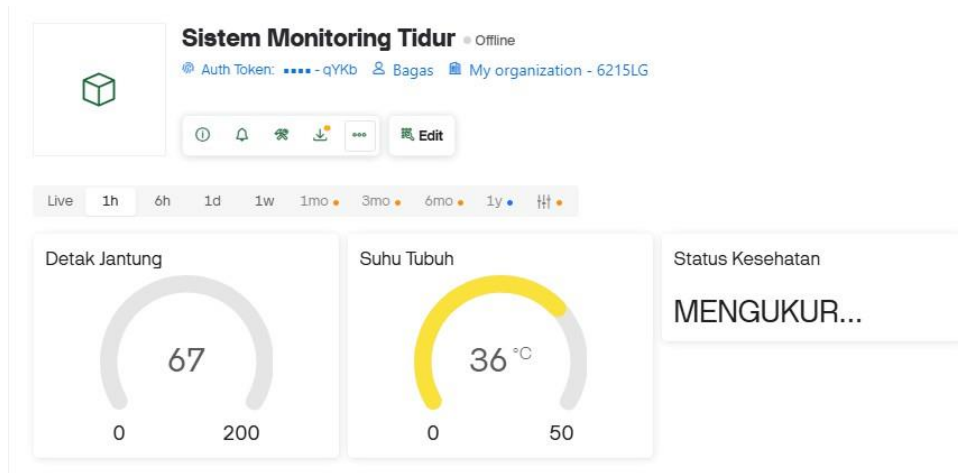

Figure 13. Blynk Application System During Sleep Monitoring.

(Description: A mockup of a smartphone screen showing the Blynk app interface, likely with gauges or value displays for BPM and Temperature, and a status indicator showing, for example, "Sehat" (Healthy).)

3.5. Evaluation

The evaluation stage is carried out to provide feedback to product users so that revisions can be made according to the evaluation results or needs that the product has not yet met. The final goal of the evaluation is to measure the achievement of development objectives. This stage is the process of testing the built application. User activity observation was conducted directly, with the user and researcher at the same location at the same time. This was done so that the researcher could get feedback from every activity performed by the user

3.5.1. Rule Viewer

In this research, the evaluation was carried out by comparing the results of the program run in Matlab software, namely the rule viewer and simulink, and then comparing them with the program run in Arduino IDE software executed using Wokwi. Here are the results.

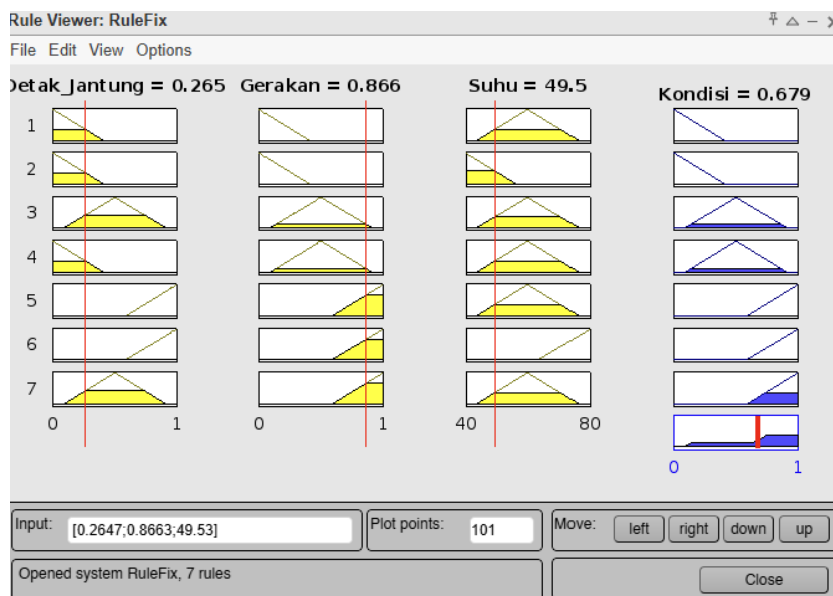

Figure 14. Rule Viewer of the IoT-Based Sleep Quality Monitoring System with Sleep Condition Analysis using Fuzzy Logic, displayed in Matlab.

(Description: The Rule Viewer in Matlab showing a specific input combination and the resulting output.)

3.5.2. Surface Viewer

The following is the display of the fuzzy surface viewer for the sleep quality Monitoring System. Here is the image:

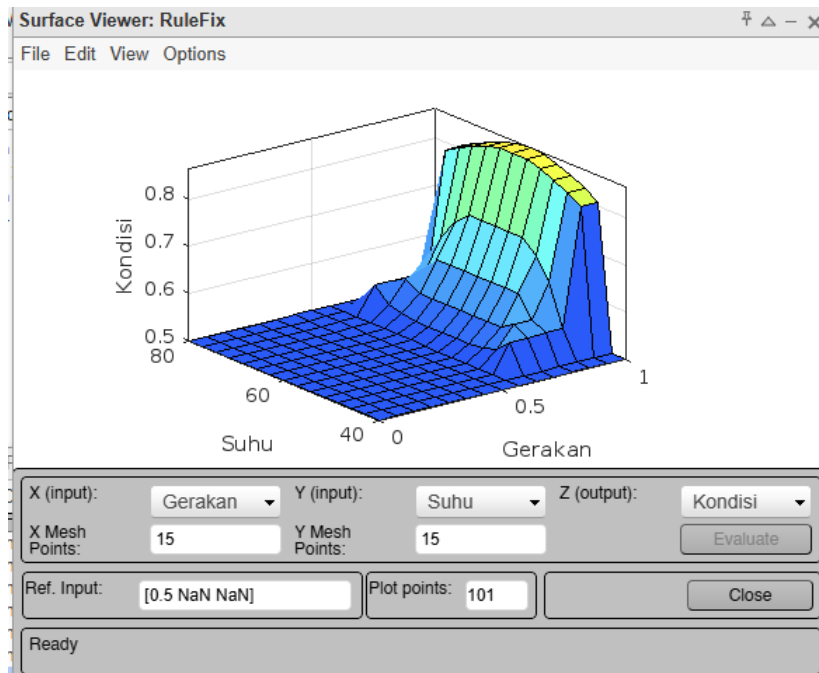

Figure 15. Surface View of the IoT-Based Sleep Quality Monitoring System with Sleep Condition Analysis using Fuzzy Logic, displayed in Matlab.

(Description: A 3D surface plot showing the relationship between two inputs (likely Heart Rate and Temperature) and the output (Sleep Condition).)

Table 6. Sample Monitoring Results

HR (BPM)	Temp (°C)	Movement	Sleep Condition
60	36.2	Low	Deep Sleep
65	36.4	Low	Light Sleep
70	36.5	Medium	Light Sleep
75	36.7	High	Awake

4. Test and Discussion

The testing methods used include:

4.1. Black Box Testing

Black Box Testing to test the main functions of the system without looking at the internal code structure. The following table shows the results of the Black Box Testing.

Table 4. Black Box Testing Results

No.	Feature Tested	Test Scenario	Test Data	Expected Result
1	Sensor Data Acquisition (Heart Rate, Temperature, Motion)	Connect sensors to the device	Physiological sensor data	Heart rate, temperature, and motion readings are detected.
2	Data Processing in Microcontroller	Stream raw data from sensors to microcontroller	Raw sensor data	Data has undergone filtering and smoothing.
3	Sleep Condition Analysis (Fuzzy Logic)	Provide varied physiological data inputs	Heart rate, temperature, motion with different thresholds	The system produces the appropriate Sleep Condition classification.
4	Data Transmission to IoT	Microcontroller sends	Processed data	Data is successfully sent

	Platform	data to IoT server	(including fuzzy results)	and stored on the IoT platform.
5	Information Display on Local LCD	Device is active and sensors are working	Real-time data	Sensor readings and basic status are displayed on the LCD.

4.2. User Acceptance Testing (UAT)

User Acceptance Testing (UAT) is the final stage in the software development process that aims to ensure that the system built meets the needs and expectations of end-users. UAT is used to assess the suitability of the system to user needs and measure user comfort when the system is used to solve the problems at hand. UAT in this study was used to assess whether the system meets the needs of end-users (stakeholders related to health and disaster preparedness).

Table 5. Graph of User Acceptance Testing Results

No	Fitur	VA	A	N	D	VD	Total
1	Is the current heart rate and temperature information accurate?	5	3	2	0	0	10
2	Are the Sleep Condition analysis results displayed easy to understand?	6	4	0	0	0	10
3	Are the recommendations for improving sleep quality helpful?	6	3	1	0	0	10
4	Is this Sleep Quality Monitoring System fast and responsive?	5	4	1	0	0	10
5	Does this system help users improve sleep quality?	4	4	2	0	0	10
	Total	26	18	6	0	0	50

(Description: A bar chart likely showing the scores for each UAT question or category)

Note: **VA** : Very Agree, **A** : Agree, **N** : Neutral, **D** : Disagree, **VD** : Very Disagree)

Percentage of system test results = (Sum of answer scores / Total maximum score) x 100%

a. Survey score result

26 x 5	=	130
18 x 4	=	72
6 x 3	=	18
0 x 2	=	0
0 x 1	=	0
Total		220

b. Maximum score

$$\text{Number of questions} \times \text{Maximum score per question} \times \text{Number of quisioners} = 5 \times 5 \times 10 = 250$$

c. System Test Result

$$(220/250) \times 100\% = 88\%$$

Based on this calculation, the User Acceptance Testing (UAT) from users yielded a score of 88% out of a total of 100%. Based on these results, users "agree" that the system built meets user-friendly principles and is quite useful in monitoring and assisting their sleep quality.

The User Acceptance Testing (UAT) results, which achieved a score of 88%, indicate that users perceive the system as useful, easy to use, and responsive. This suggests that the system has strong potential for real-world application, particularly for personal and home-based sleep monitoring. From a practical perspective, the system provides an accessible alternative to traditional clinical methods such as polysomnography (PSG), which are expensive and require specialized environments. By leveraging IoT technology and mobile interfaces, users can monitor their sleep conditions independently and continuously.

4.3. Discussion

This study presents an IoT-based sleep quality monitoring system integrating physiological sensors and a Mamdani fuzzy inference model for real-time sleep condition analysis. The discussion focuses on system performance, analytical capability of the fuzzy model, comparison with existing approaches, and identified limitations.

The experimental results demonstrate that the proposed system is capable of acquiring and transmitting physiological data, including heart rate, body temperature, and movement, in real time. The integration of the ESP32 microcontroller with the Blynk IoT platform enables low-latency communication and stable data visualization through a mobile interface. The successful execution of all functional modules in Black Box Testing confirms that the system architecture is robust and operates according to design specifications. Moreover, the system shows good modularity, where each component (sensor, processing unit, and communication module) operates independently yet cohesively. This modular design enhances system scalability and allows future integration with additional sensors such as SpO₂ or respiration rate sensors.

The implementation of the Mamdani fuzzy inference system demonstrates the capability to handle uncertainty and variability in physiological data. Unlike rigid threshold-based methods, fuzzy logic enables gradual transitions between sleep conditions, which better reflects real human physiological behavior during sleep. The use of linguistic variables such as *low*, *normal*, and *high* allows the system to model expert knowledge in a human-readable form. The inference process successfully classifies sleep conditions into *Healthy*, *Warning*, and *Critical* states based on multi-parameter inputs. However, the current rule base consists of only seven rules, which may limit the granularity and sensitivity of the classification. While sufficient for basic condition detection, a more comprehensive rule set could improve system responsiveness to complex physiological variations.

Compared to existing IoT-based sleep monitoring systems, the proposed approach offers a lightweight and cost-effective alternative. Many recent studies employ machine learning or deep learning techniques for sleep analysis, which typically require high computational resources, large datasets, and cloud-based processing infrastructures. In contrast, the proposed fuzzy-based system operates efficiently on an embedded platform (ESP32), making it suitable for real-time applications with limited hardware resources. This aligns with prior research indicating that fuzzy logic is effective for decision-making in resource-constrained IoT environments. However, machine learning-based approaches generally achieve higher classification accuracy and can model complex nonlinear relationships more effectively. Additionally, wearable-based systems integrated with advanced biosensors provide richer datasets, enabling more detailed sleep stage classification (e.g., REM, deep sleep, light sleep). Thus, the proposed system trades off analytical complexity for simplicity, interpretability, and cost efficiency.

5. Conclusion

Based on the results of the research and development conducted using the ADDIE method, it can be concluded that the IoT-based sleep quality Monitoring System with Sleep Condition analysis using fuzzy logic has been successfully developed. This system has proven capable of acquiring physiological data, including heart rate and body temperature, in real-time through Wokwi System and sending this data to the Blynk platform as a remote monitoring interface. The implementation of the Mamdani Fuzzy Logic algorithm on the ESP32 microcontroller also runs effectively in processing sensor data uncertainty, allowing the system to classify the user's health condition into "Healthy", "Warning", or "Critical" status accurately according to the established rules.

Functionally, Black Box Testing confirmed that all main features of the system, from sensor reading to data transmission, functioned according to the design scenarios. The feasibility of this system is further strengthened by the results of the User Acceptance Testing (UAT), which obtained a percentage score of 88 %. This figure indicates that the system is considered highly feasible, easy to use (user-friendly), and beneficial by users. Thus, this system has great potential as an alternative solution that is more practical and affordable for independent sleep quality monitoring compared to complex conventional methods.

4. References

- [1] M. N. I. M. Shahrur, I. S. M. Isa, N. L. A. M. S. Azyze, H. M. Nasir, and T. Sutikno, "Development of an IoT-based sleep pattern Monitoring System for sleep disorder detection," *Indonesian Journal of Electrical Engineering and Computer Science*, vol. 36, no. 2, pp. 777–784, Nov. 2024, doi: 10.11591/ijeecs.v36.i2.pp777-784.
- [2] M. M. Lutfi, M. Andri Saputra, V. Indrawan Putranto, and R. Ridho, "SIMULASI SISTEM PENYIRAM TANAMAN HIAS MENGGUNAKAN KONTROL LOGIKA FUZZY BERBASIS INTERNET OF THINGS," *Jurnal TRANSFORMASI*, vol. 20, no. 1, pp. 1–19, 2024.
- [3] M. Lutfi and A. Kristanto, "TRAINER FUZZY SEBAGAI SARANA PRAKTIKUM MAHASISWA," *Transformasi*, vol. 18, no. 1, Jan. 2022, doi: 10.56357.
- [4] Lutfi, I. N. Azizah, D. Nataliya, F. Maghfiroh, and Y. Febriani, "The IoT System of Watering System for Vanilla Cultivation using DHT11 and Soil Moisture Sensors with Fuzzy Logic Control," *Innovation, Technology, and Entrepreneurship Journal*, vol. 2, no. 2, pp. 105–118, Aug. 2025, doi: 10.31603/itej.14435.
- [5] M. M. Lutfi, "Digital Startup _Veggie Fresh_ using Code Igniter and Design Thinking Method," *ITEJ (Innovation, Technology and Entrepreneur Journal)*, vol. 2, no. 1, pp. 1–14, Jun. 2024, doi: 10.31603.
- [6] Lutfi, K. Kanafi, and R. Syaifullah, "It Capacity Improvement for Swimming Coaches and Assistant Coaches for Swimming Performance Coaching at the Indonesian Aquatic Federation in Magelang City," *Unram Journal*

- of Community Service*, vol. 5, no. 4, pp. 345–351, Dec. 2024, doi: 10.29303/ujcs. v5i4.701.
- [7] M. Z. Rahman, M. A. Akbar, V. Leiva, A. Tahir, M. T. Riaz, and C. Martin-Barreiro, “An intelligent health monitoring and diagnosis system based on the internet of things and fuzzy logic for cardiac arrhythmia COVID-19 patients,” *Comput. Biol. Med.*, vol. 154, Mar. 2023, doi: 10.1016/j.combiomed.2023.106583.
- [8] M. R. Rahmatulloh, N. Indroasyoko, and H. Khoirunnisa, “PENERAPAN FUZZY LOGIC DALAM SISTEM PEMANTAUAN VITAL SIGN BERBASIS INTERNET OF THINGS,” *The Indonesian Journal of Computer Science*, vol. 13, no. 4, Jul. 2024, doi: 10.33022/ijcs. v13i4.4112.
- [9] A. Probha, P. S. Thind, A. D. Gupta, B. R. Prathap, and K. P. Kumar, “Real-Time Stress Monitoring Using IoT Wearable Sensors and Machine Learning,” in *Smart Innovation, Systems and Technologies*, Springer Science and Business Media Deutschland GmbH, 2025, pp. 331–342. doi: 10.1007/978-981-97-7717-4_23.